

CAPACITY	SYMBOL / SERIAL NO.	CIRCUIT DIAGRAM
AC100-240V, 50/60Hz		
25W x 2		

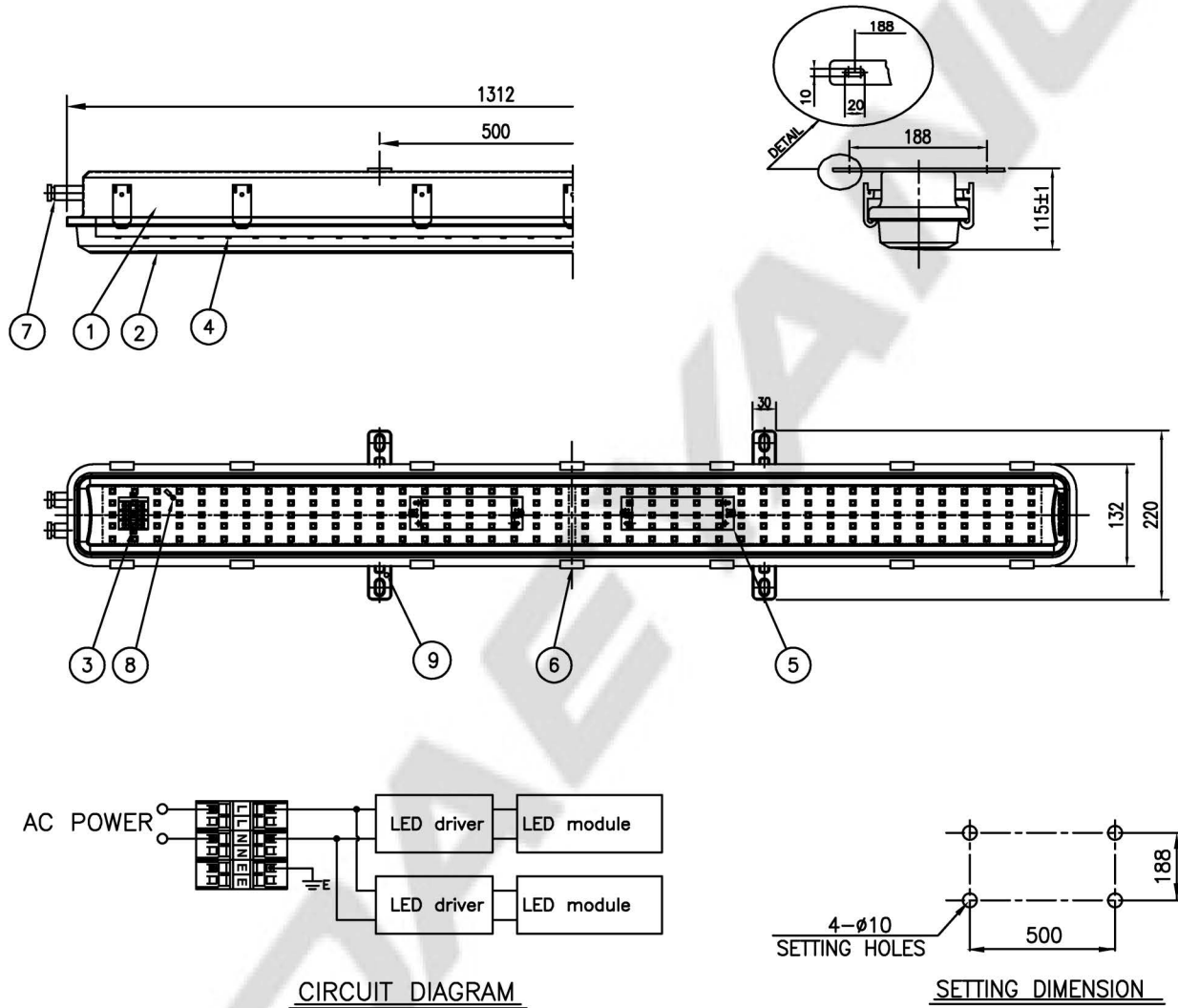

9	OUTSIDE EARTH BOLT	STAINLESS STEEL304	1	M5					
8	INSIDE EARTH BOLT	STAINLESS STEEL304	1	M4	4	LED module	-	2	5,000K
7	CABLE GLAND	BRASS	2	Ø14~Ø17.5	3	TERMINAL BLOCK	NYLON	1	
6	LATCH	STAINLESS STEEL316L	14		2	GLOBE	POLYCAR-BONATE	1	MILKY
5	LED driver	-	2		1	BODY	STAINLESS STEEL316L	1	
NO	NAME OF PARTS	MATERIAL	Q'TY	REMARKS	NO	NAME OF PARTS	MATERIAL	Q'TY	REMARKS

APPROVED	B. K. KIM	UNIT	MM	TITLE; LED CEILING LIGHT (SURFACE TYPE) FOR MARINE USE			
CHECKED		SCALE	N/S				
DRAWING	B. I. KIM	COLOR	N-9.3				
DATE	2015.12.04	IP	67				
				MODEL NO.	LEB225WS-0550UWNM2GLw17QC50	WEIGHT	7.7 Kg
				DWG NO.	L01450161	SHEET NO.	23